

LIGHT

The LT7A20 is an acceleration sensor IC, which features abundant functions, low power dissipation, small size, and precision measurement.

It communicates with MCU through I²C/SPI interface, the acceleration measurement data can be accessed in interrupt mode or inquiry mode. INT1 and INT2 provide many auto-detected interrupt signals which are suitable to many motion detection fields, interrupt source include 6D/4D direction detection interrupt signal, free fall detection interrupt signal, sleep and wake up detection interrupt signal, and single/double click detection interrupt signal. A high-precision calibration module is available within the IC to accurately compensate the sensor's offset error and gain error. It has dynamically user selectable full scales of 2G/ 4G/ 8G/ 16G and it is capable of measuring accelerations with output data rates from 1Hz to 400Hz.

A self-test capability allows the user to check the functioning of the sensor in the final application. The available tilt calibration function is able to compensate the tilt caused by SMT or PCB installation, not

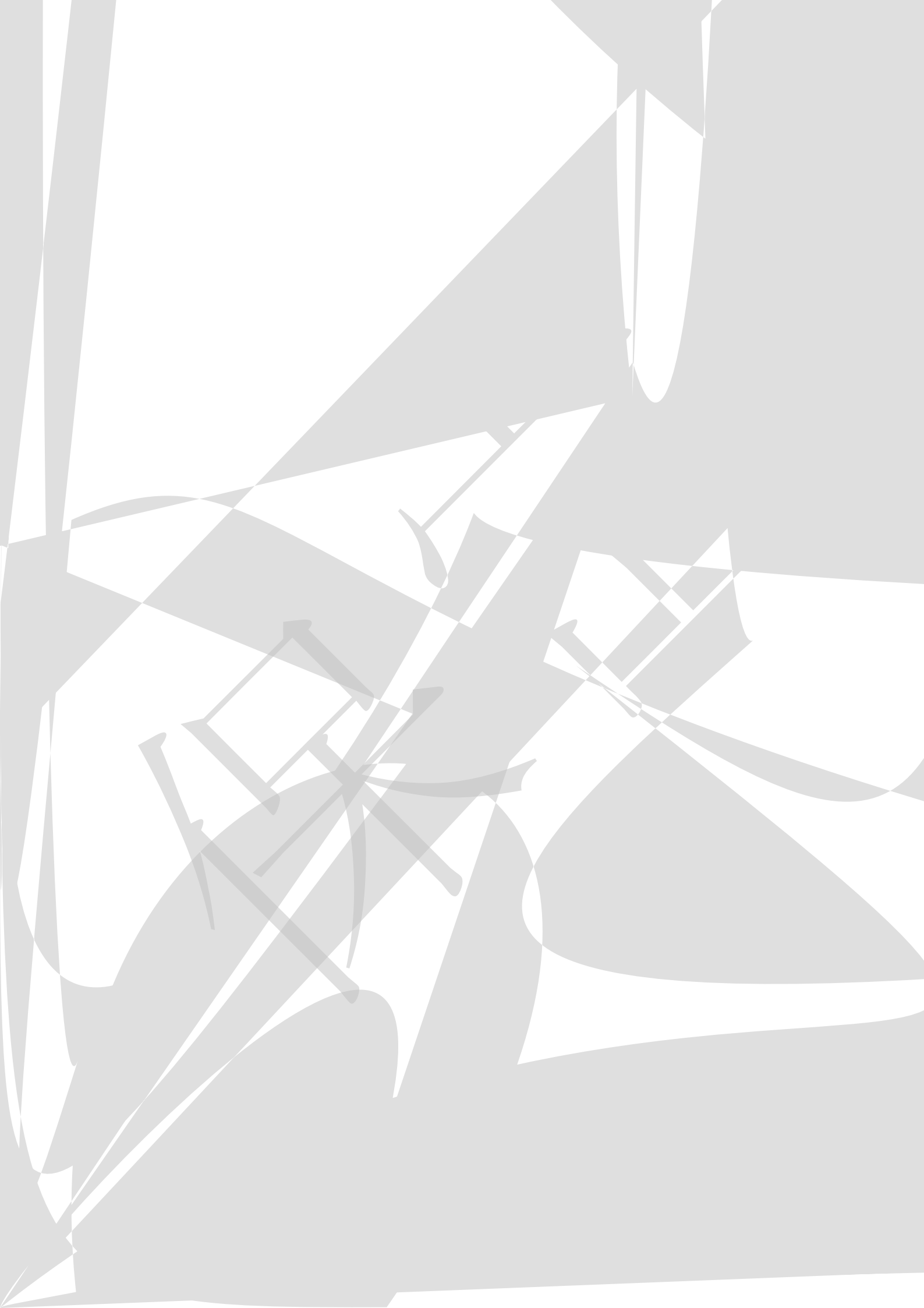

LIGHT

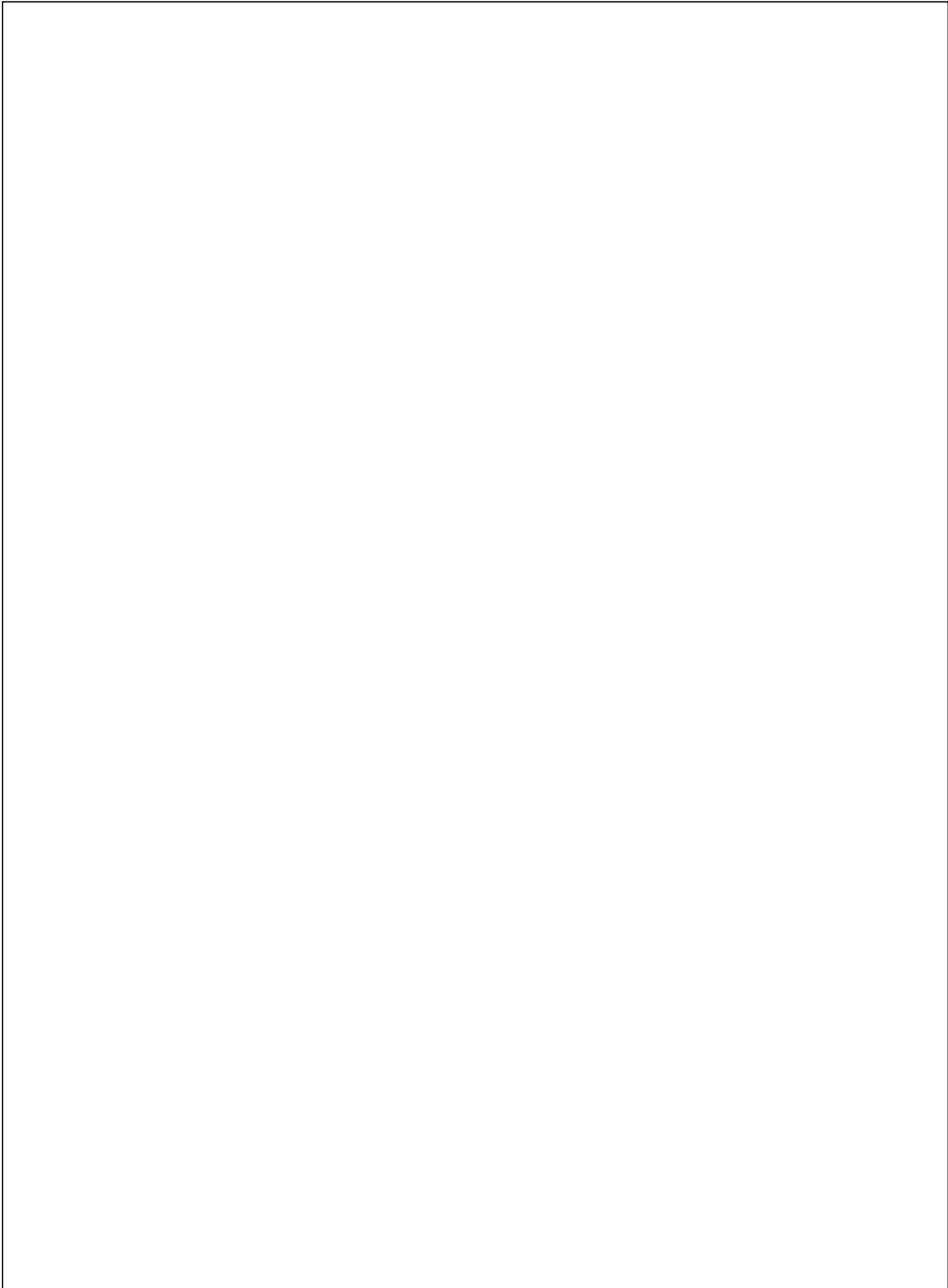

	ODR3	ODR= 50Hz	--	50	--	
	ODR4	ODR= 100Hz	--	100	--	
	ODR5	ODR= 200Hz	--	200	--	
	ODR6	ODR= 400Hz	--	400	--	
Turn-on time	T_{on}	ODR=100Hz	--	1	--	ms
Operating temperature range	T_{opr}	--	-40	--	+85	°C

SCL clock frequency	$f_{(SCL)}$	0	100	0	400	KHz
SCL clock low time	$t_{w(SCLL)}$	4.7	--	1.3	--	μ s
SCL clock high time	$t_{w(SCLH)}$	4.0	--	0.6	--	
SDA setup time	$t_{su(SDA)}$	250	--	100	--	ns
SDA data hold time	$t_h(SDA)$	0.01	3.45	0.01	0.9	μ s
SDA/SCL rise time	$t_r(SDA)$ $t_r(SCL)$	--	1000	$20+0.1C_b$	300	ns
SDA/SCL fall time	$t_f(SDA)$ $t_f(SCL)$	--	300	$20+0.1C_b$	300	ns
START condition hold time	$t_h(ST)$	4	--	0.6	--	μ s
Repeated START condition setup time	$t_{su(SR)}$	4.7	--	0.6	--	
STOP condition setup time	$t_{su(SP)}$	4	--	0.6	--	
Bus free time between STOP and START conditions	$t_w(SP:SR)$	4.7	--	1.3	--	

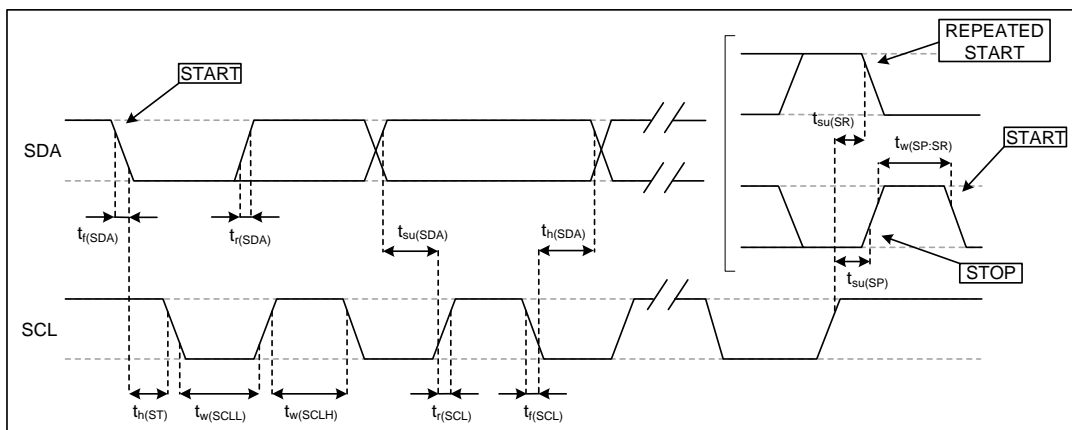

I²C slave timing diagram



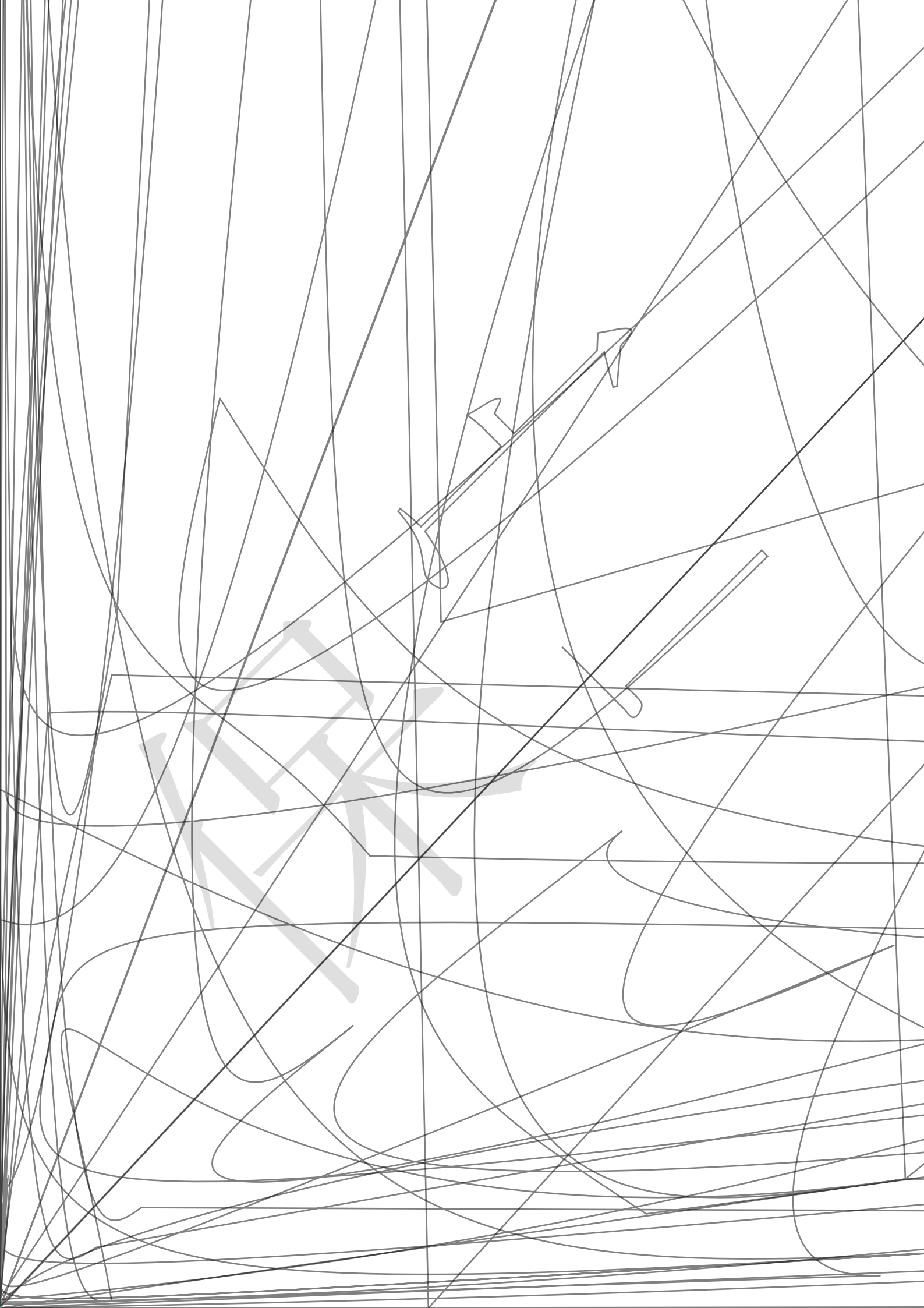

The LT7A20 is an ultra compact low-power, digital output 3-axis linear accelerometer packaged in LGA. The complete device includes a mechanical sensing unit and an integrated circuit interface able to take the information from the sensing unit and to provide a signal to the external MCU through I²C or SPI interface.

The mechanical sensing unit consists of suspended mass and silicon frame. The suspended mass are attached to the silicon frame in a few points called anchors and are free to move in the direction of the sensed acceleration. To be compatible with the traditional packaging techniques a cap is placed on top of the sensing element to avoid blocking the moving parts during the moulding phase of the plastic encapsulation. When an acceleration is applied to the sensor the proof mass displaces from its nominal position, causing an imbalance in the capacitive half-bridge. This imbalance is measured using charge integration in response to a voltage pulse applied to the capacitor.

At steady state the nominal value of the capacitors are few pF and when an acceleration is applied the maximum variation of the capacitive load is in fF range.

The complete measurement chain is composed by a low-noise capacitive amplifier which converts the capacitive unbalancing of the MEMS sensor into an analog voltage that is finally available to the user by analog-to-digital converters. The acceleration data may be accessed through an I²C/SPI interface thus making the device particularly suitable for direct interfacing with a microcontroller. The LT7A20 features a data-ready signal (RDY) which indicates when a new set of measured acceleration data is available thus simplifying data synchronization in the digital system that uses the device. It may also be configured to generate an inertial Wake-Up and Free-Fall interrupt signal accordingly to a programmed acceleration event along the enabled axes.

The IC interface is factory calibrated for sensitivity (S_0) and Zero-g level ($T_{Y_{Off}}$).

The trimming values are stored inside the device in EEPROM. Any time the device is turned on, the trimming parameters are downloaded into the registers to be used during the normal operation. This allows to use the device without further calibration.

lower than threshold value, then the interrupt signal is generated, and corresponding state register is set.

Sleep detection: when the sensor output keeps constant within given threshold range for a certain time, the sensor is judged as no action, corresponding state signal is set and interrupt signal is generated, the system enters low power mode. Refer to application note for details.

Wake up detection; when the sensor output becomes higher than the threshold value and lasts for a certain time, the sensor is judged as being action, corresponding state signal is set and interrupt signal is generated, the system restores normal operating mode. Refer to application note for details.

The sensor judges whether the output reaches conditions for single/double click according to given threshold value and time, sets corresponding state signal and generates interrupt signal. Refer to application note for details.

9.1 Sensitivity

Sensitivity describes the gain of the sensor and can be determined e.g. by applying 1g acceleration to it. As the sensor can measure DC accelerations this can be done easily by pointing the axis of interest towards the center of the earth, noting the output value, rotating the sensor by 180 degrees (pointing to the sky) and noting the output value again. By doing so, $\pm 1g$ acceleration is applied to the sensor. Subtracting the larger output value from the smaller one and dividing the result by 2, leads to the actual sensitivity of the sensor. This value changes very little over temperature and also time. The Sensitivity tolerance describes the range of sensitivities of a large population of sensors.

9.2 Zero-g level

Zero-g level Offset ($T_{Y_{Off}}$) describes the deviation of an actual output signal from the ideal output signal if no acceleration is present. A sensor in a steady state on a horizontal surface measure 0g in X axis and 0g in Y axis whereas the Z axis measure 1g. The output is ideally in the middle of the dynamic range of the sensor (content of OUT registers 00h, data expressed as 2's complement number). A deviation from ideal value in this case is called Zero-g offset. Offset is to some extent a result of stress to MEMS sensor and therefore the offset can slightly change after mounting the sensor onto a printed circuit board or exposing it to extensive mechanical stress. Offset changes little over temperature, "Zero-g offset" is called "temperature offset".

9.3 Self test

Self Test allows to check the sensor functionality without moving it. The Self Test function is off when the self-test bit is programmed to '0'. When the self-test bit is programmed to '1' an actuation force is applied to the sensor, simulating a definite input acceleration. In this case the sensor outputs exhibit a change in their DC levels which are related to the selected full scale through the device sensitivity. When self test is activated, the device output level is given by the algebraic sum of the signals produced by the acceleration acting on the sensor and by the electrostatic test-force. If the output signals change within the amplitude specified inside the range, then the sensor is working properly.

The Slave address (SAD) associated to the LT7A20 is 0011xxxb. Data transfer with ACK signal is mandatory. The transmitter must release the SDA line in the 9th CLK. The receiver must then pull the data line LOW to complete one ACK return. A receiver which has been addressed is obliged to generate an acknowledge after each byte of data has been received. The I²C embedded inside the LT7A20 behaves like a slave device and adheres to similar standard IIC protocol. After the start condition (ST) a slave address is sent, once a slave acknowledge (SAK) has been returned, an 8-bit sub-address is transmitted: the 7 LSb represent the actual register address while the MSB enables address auto increment. If the MSb of the SUB field is 1, the SUB (register address) is automatically incremented to allow multiple data read/write.

The slave address is completed with a Read/Write bit. If the bit is '1' (Read), a repeated START (SR) condition is issued after the two sub-address bytes; if the bit is '0' (Write) the Master will transmit to the slave with direction unchanged.

I²C address

Floating/logic high	0x19	0x32(W) 0x33(R)	Non leakage current
Logic low	0x18	0x30(W) 0x31(R)	Turn off internal pull-up resistor

Transfer when master is writing one byte to slave

Master	ST	SAD+W		SUB		DATA		SP
Slave			SAK		SAK		SAK	

Transfer when master is writing multiple bytes to slave

Master	ST	SAD+W		SUB		DATA		DATA		SP
Slave			SAK		SAK		SAK		SAK	

Transfer when master is receiving (reading) one byte of data from slave

Master	ST	SAD+W		SUB		SR	SAD+R		MAK		MAK		NMAK	SP
Slave			SAK		SAK			SAK	DATA		DATA		DATA	

Data are transmitted in byte format (DATA). Each data transfer contains 8 bits. The number of bytes transferred per transfer is unlimited. Data is transferred with the Most Significant bit (MSb) first. If a receiver can't receive another complete byte of data until it has performed some other function, it can hold the clock line, SCL LOW to force the transmitter into a wait state. Data transfer only continues when the receiver is ready for another byte and releases the data line. If a slave receiver doesn't acknowledge the slave address (i.e. it is not able to receive because it is performing some real time function) the data line must be left HIGH by the slave. The Master can then abort the transfer. A LOW to HIGH transition on the SDA line while the SCL line is HIGH is defined as a STOP condition. Each data transfer must be terminated by the generation of a STOP (SP) condition.

In order to read multiple bytes, it is necessary to assert the most significant bit of the subaddress field. In other words, SUB(7) must be equal to 1 while SUB(6-0) represents the address of first register to be read.

For example, after the sensor is configured to work, continuous reading of triaxial data (register address 0x28 ~ 0x2d) is adopted, and the address of register data is 0xA8 (0x28 | 0x80).

LIGHT

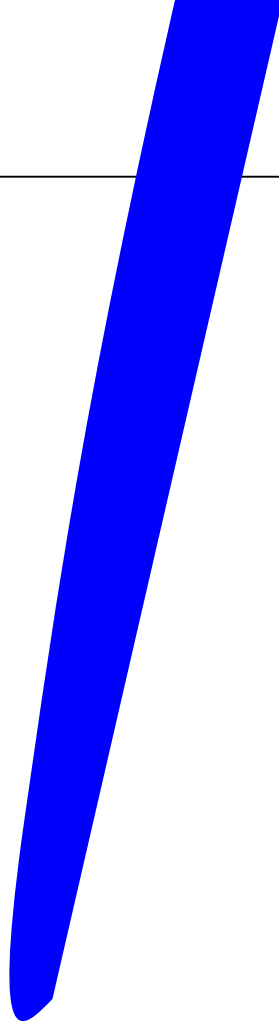

G

Part No. | LT7A20

10.2.2 SPI write

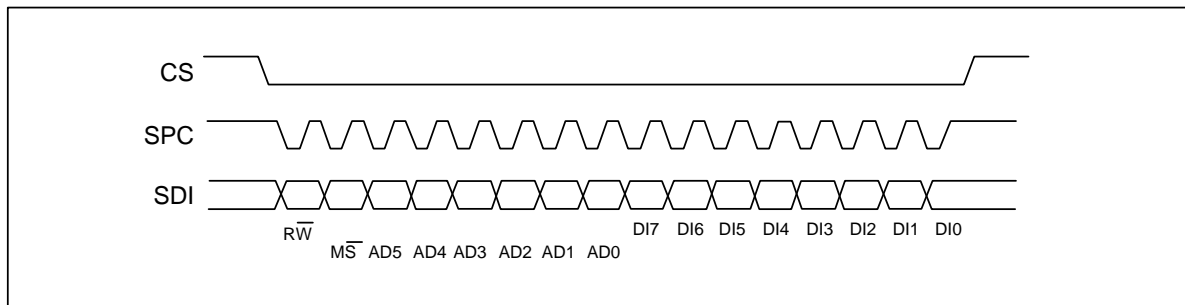

SPI write protocol

The SPI write command is performed with 16 clock pulses. Multiple byte write command is performed adding blocks of 8 clock pulses at the pervious one.

Bit0: WRITE bit, the value is 0.

Bit1: \overline{MS} bit. When 0, do not increment address, when 1, increment address for multiple writing.

Bit2-7: address AD(5:0), the register address.

Bit8-15: data DI(7:0) (write mode), the data that is written inside the slave device (MSB first).

Bit16-....: data DI(...:8) (write mode), further data in multiple byte writing (MSB first).

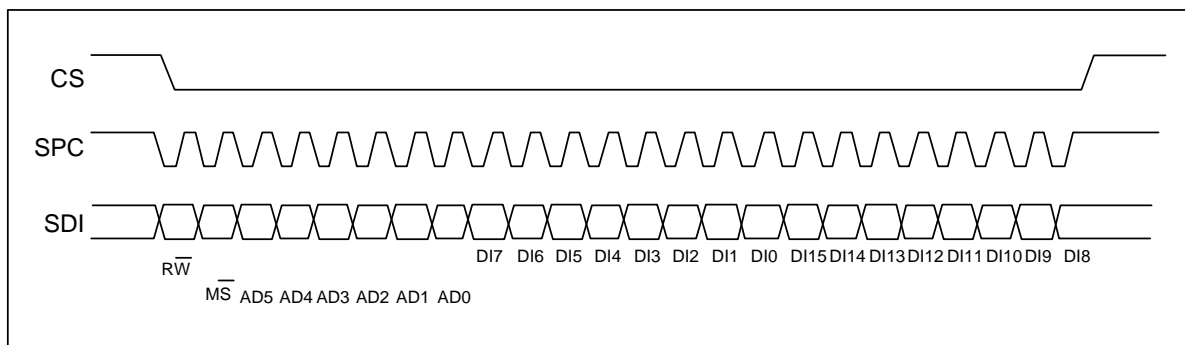

Multiple bytes SPI write protocol (2 bytes as an example)

10.2.3 SPI read in 3-wire mode

3-wire mode is entered by writing 1 to SIM bit. Only three signals lines are used in both 4-wire mode and 3-wire mode, and the logic and timing are both the same in these two modes, hence, it is able to configure the slave as 3-wire mode through 4-wire write mode.



LIGHT

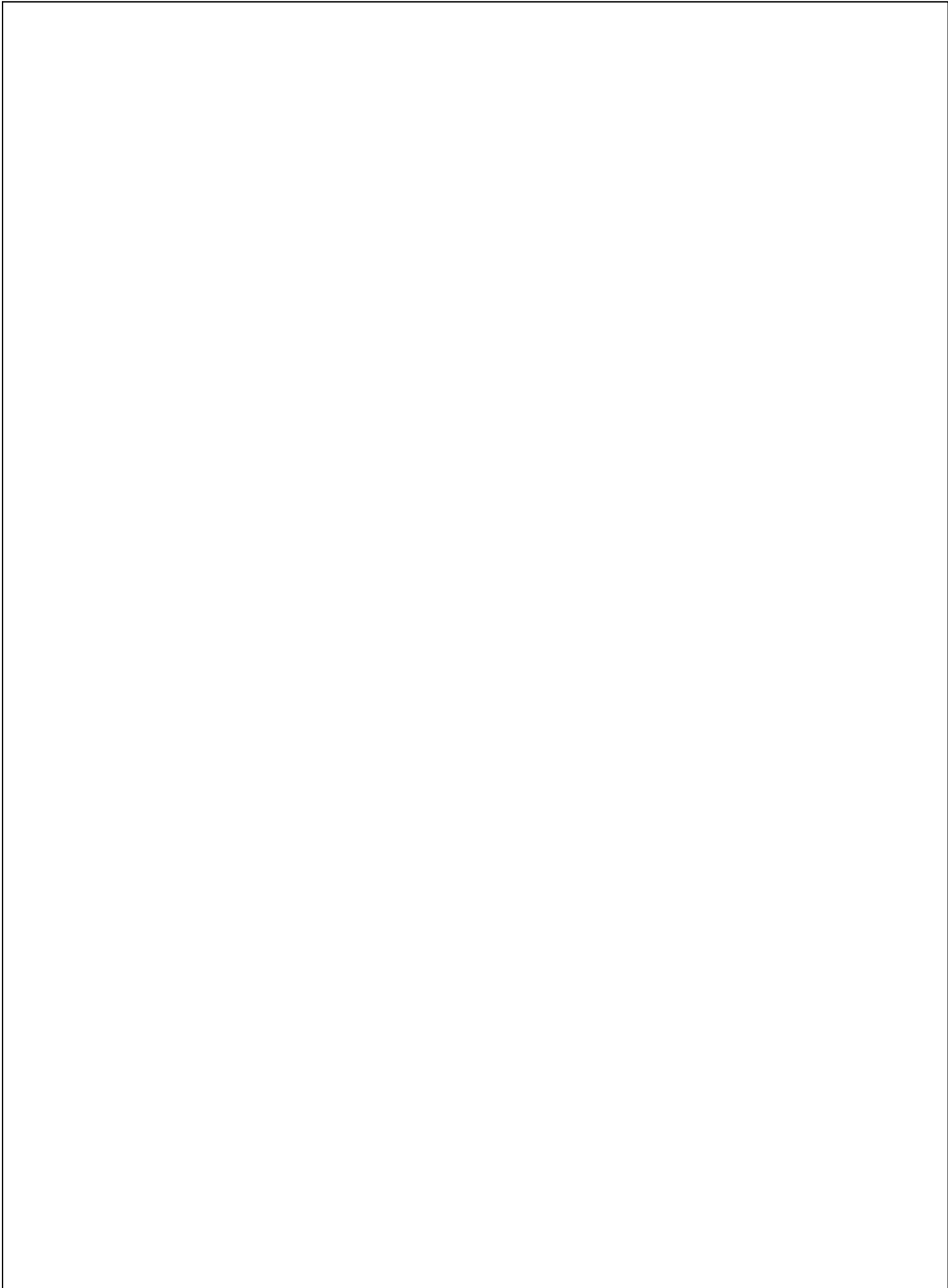

HPM1	HPM0	High pass filtering mode
0	0	Normal mode (read high pass filtering is reset automatically)
0	1	Filtering reference signal
1	0	Normal mode
1	1	Interrupt event automatic reset

B7

B6

B5

B4

B3

B2

B1

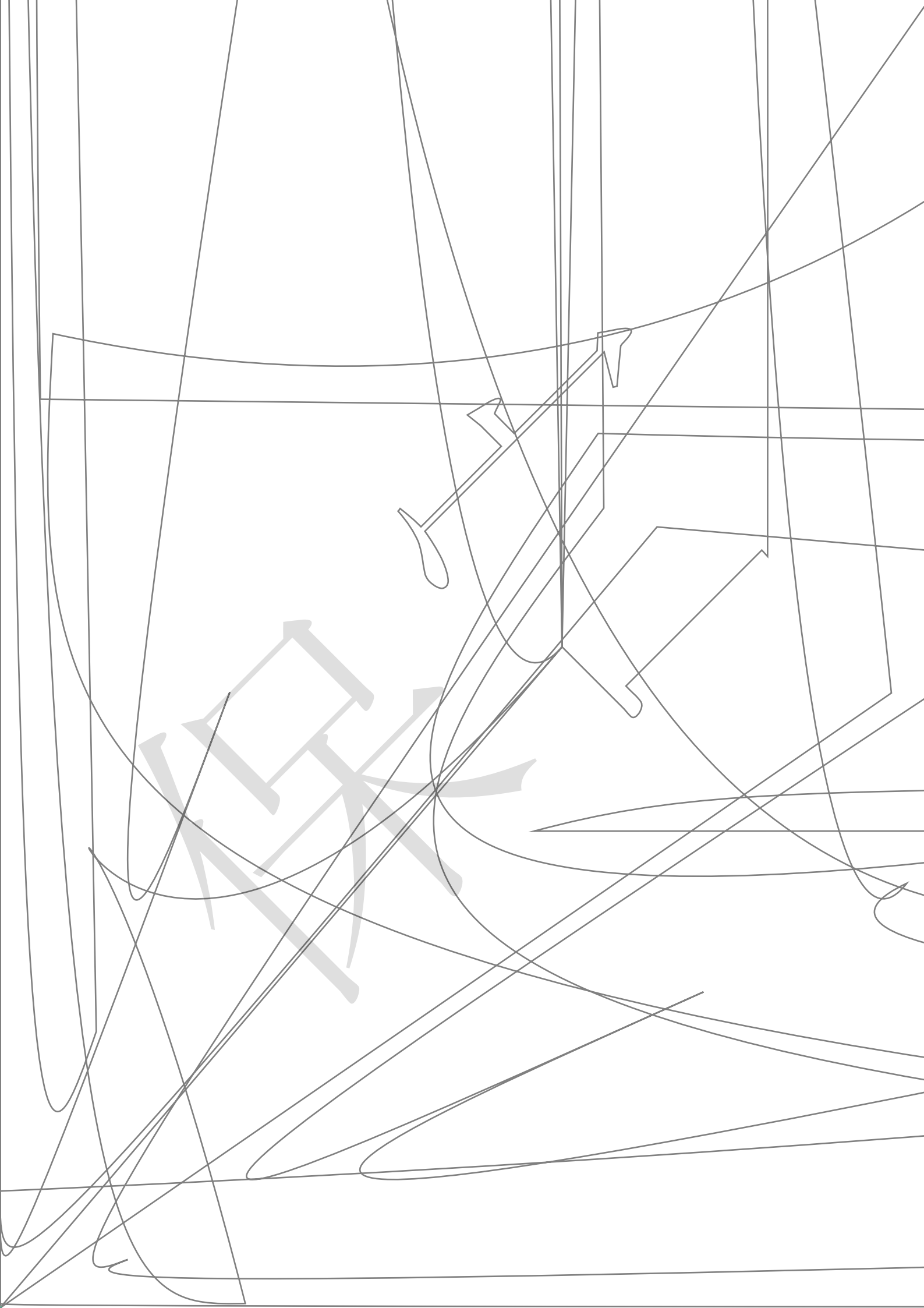

Z-axis accelerometer value, data is expressed as 2's complement number.

B7	B6	B5	B4	B3	B2	B1	B0
AOI	6D	ZHIE/ ZUPE	ZLIE/ ZDOWNE	YHIE/ YUPE	YLIE/ YDOWNE	XHIE/ XUPE	XLIE/ XDOWNE

AOI	And/or interrupt. Default value: 0. Refer to "interrupt mode"
6D	6D test enable. Default value: 0. Refer to "interrupt mode"
ZHIE/ ZUPE	Z-axis high interrupt or Z-axis direction test interrupt enable . Default value: 0. (0:Interrupt is disable; 1: interrupt is enable)
ZLIE/ ZDOWNE	Z-axis low interrupt or Z-axis direction test interrupt enable . Default value: 0. (0:Interrupt is disable; 1: interrupt is enable)
YHIE/ YUPE	Y-axis high interrupt or Y-axis direction test interrupt enable . Default value: 0. (0:Interrupt is disable; 1: interrupt is enable)
YLIE/ YDOWNE	Y-axis low interrupt or Y-axis direction test interrupt enable . Default value: 0. (0:Interrupt is disable; 1: interrupt is enable)
XHIE/ XUPE	X-axis high interrupt or X-axis direction test interrupt enable . Default value: 0. (0:Interrupt is disable; 1: interrupt is enable)
XLIE/ XDOWNE	X-axis low interrupt or X-axis direction test interrupt enable . Default value: 0. (0:Interrupt is disable; 1: interrupt is enable)

AOI	6D	Interrupt mode
0	0	Or interrupt event
0	1	6D Motion Recognition
1	0	And interrupt event
1	1	6D position detection

YL	Y-axis low. Default value: 0. (0: no interrupt ; 1: Y-axis low event occurs)
XH	X-axis high. Default value: 0. (0: no interrupt ; 1: X-axis high event occurs)
XL	X-axis low. Default value: 0. (0: no interrupt ; 1: X-axis low event occurs)

B7	B6	B5	B4	B3	B2	B1	B0
0	THS6	THS5	THS4	THS3	THS2	THS1	THS0

THS6 - THS0	Interrupt 1 threshold. Default value: 000 0000 1LSB=16mg @ FS=2g 1LSB=32mg @ FS=4g 1LSB=64mg @ FS=8g 1LSB=128mg @ FS=16g
-------------	--

B7	B6	B5	B4	B3	B2	B1	B0
0	D6	D5	D4	D3	D2	D1	D0

D6 - D0	Duration count value. Default value: 000 0000
---------	---

Min. duration of interrupt 1 is recognized through D6 - D0 position recognition.

Max. duration and step is counted with clock of ODR.

B7	B6	B5	B4	B3	B2	B1	B0
AOI	6D	ZHIE/ ZUPE	ZLIE/ ZDOWNE	YHIE/ YUPE	YLIE/ YDOWNE	XHIE/ XUPE	XLIE/ XDOWNE

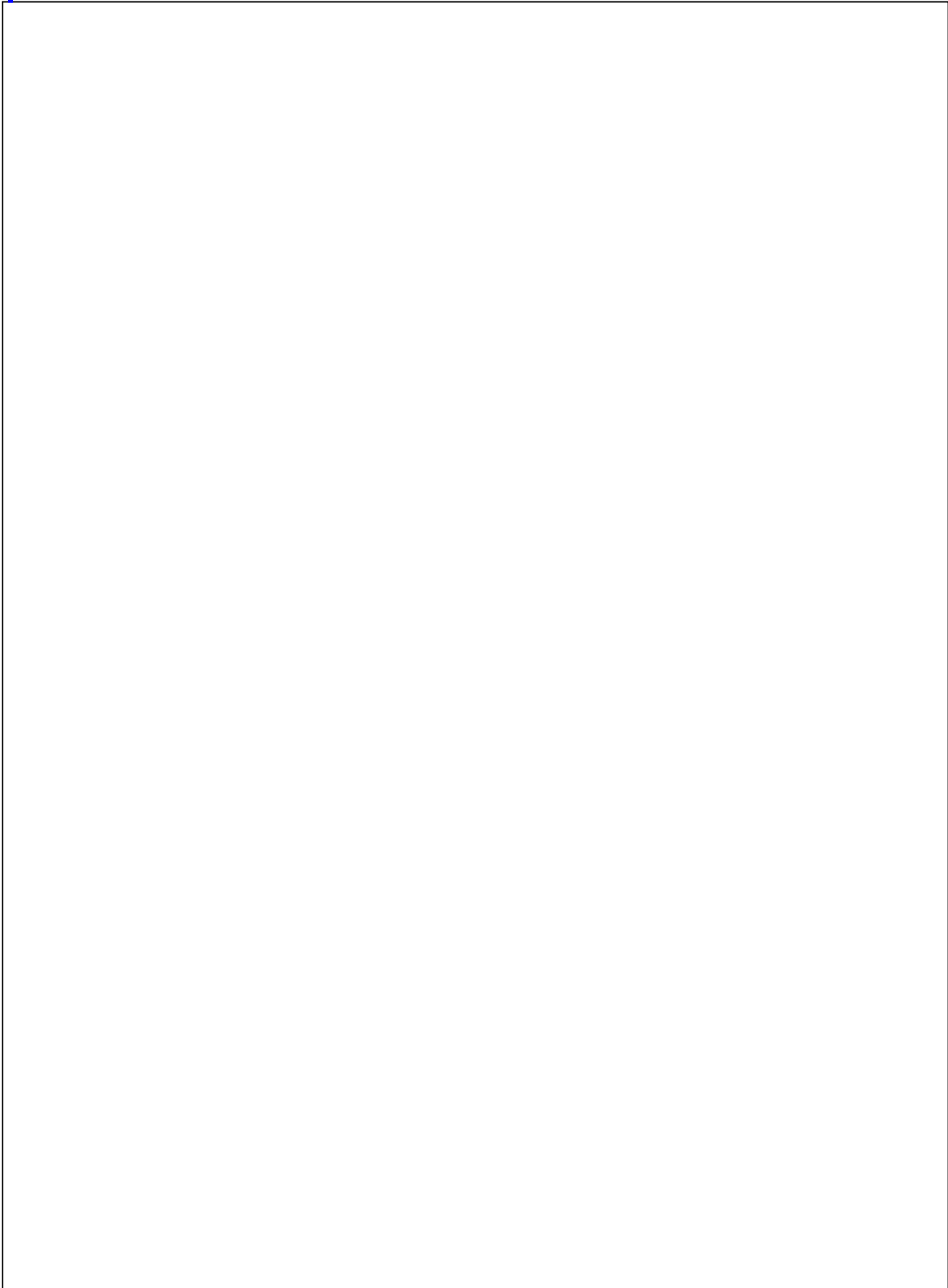

Part No.	LT7A20	Page	24 of 28
-----------------	---------------	-------------	-----------------

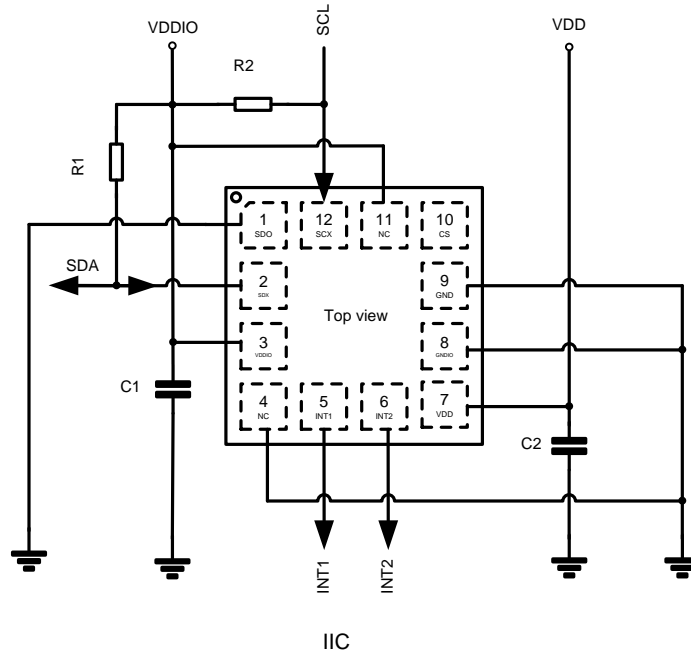

Note: when the SDO (Pin1) pin is grounded, the pull-up resistance leakage will be caused. Suspended or connected to high level is recommended, and internal pull-up function can also be turned off through IIC configuration.

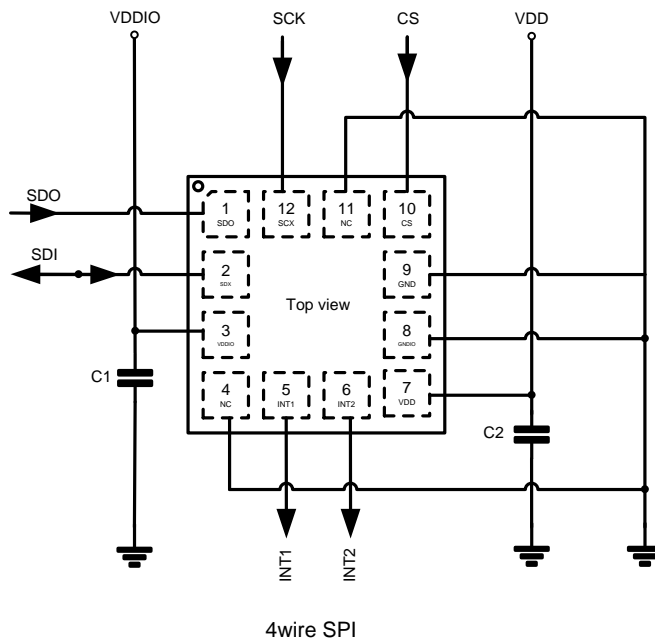

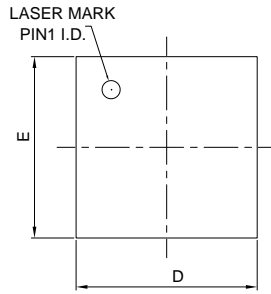

TOP VIEW

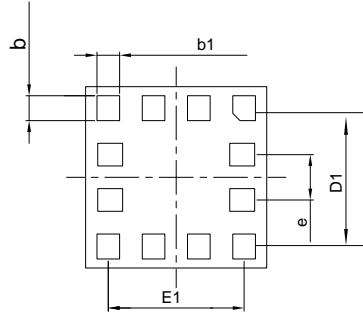

BOTTOM VIEW

A	0.930	1.050
A3	0.650	0.850
c	0.130	0.300
D	1.900	2.000 2.100
E	1.900	2.000 2.100

E1	1.500 BSC	
b	0.275	
b1	0.200	0.250 0.300
e	0.450	0.500 0.550

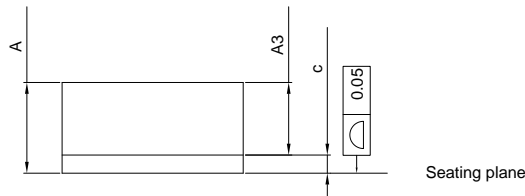

The instructions are subject to change without notice. Customers should obtain the latest relevant information before placing orders and should verify that such information is complete and current.

Our products are consumer electronic products, and / or civil electronic products.

When using our products, please do not exceed the maximum rating of the products, otherwise the reliability of the whole machine will be affected. There is a certain possibility of failure or malfunction of any semiconductor product under specific conditions. The buyer is responsible for complying with safety standards and taking safety measures when using our products for system design, sample and whole machine manufacturing, so as to avoid potential failure risk that may cause personal injury or property loss.

It is strongly recommended to identify the trademark when buying our products. Please contact us if there is any question.

When exporting, using and reselling our products, buyer must comply with the international export control laws and regulations of China, the United States, the United Kingdom, the European Union and other countries & regions.

Product promotion is endless, our company will wholeheartedly provide customers with better products!